

Product Details

Electrical Connection : 10 Amp Plug & Lead (supplied)

Electrical Rating : 240v, 10amps, 2400w,
: 4 elements @ 600w

Waste : 13mm with 19mm drain
and 1/2" BSP mini cistern cock

Unit Controls : Switch for main power
: Thermostat with dial thermometer

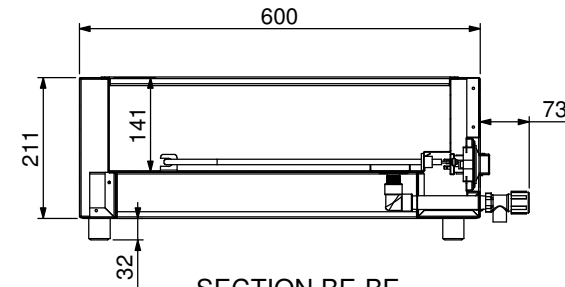
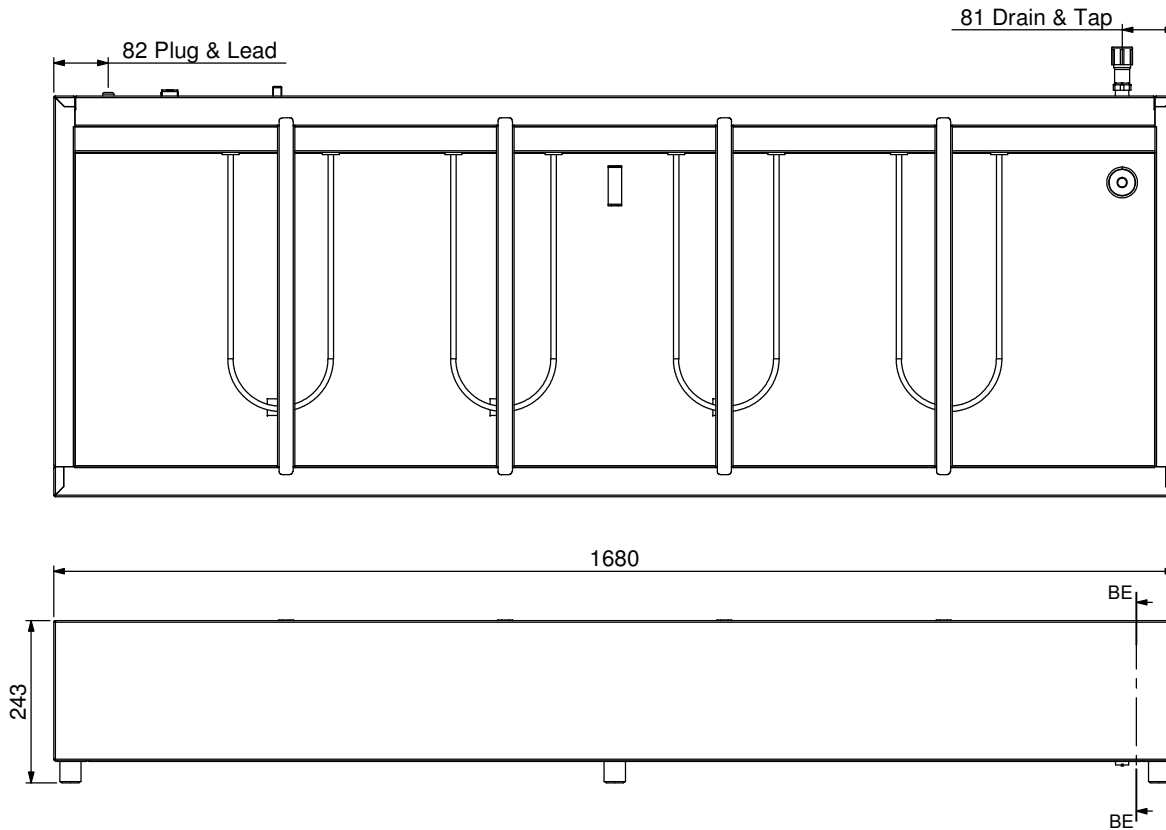
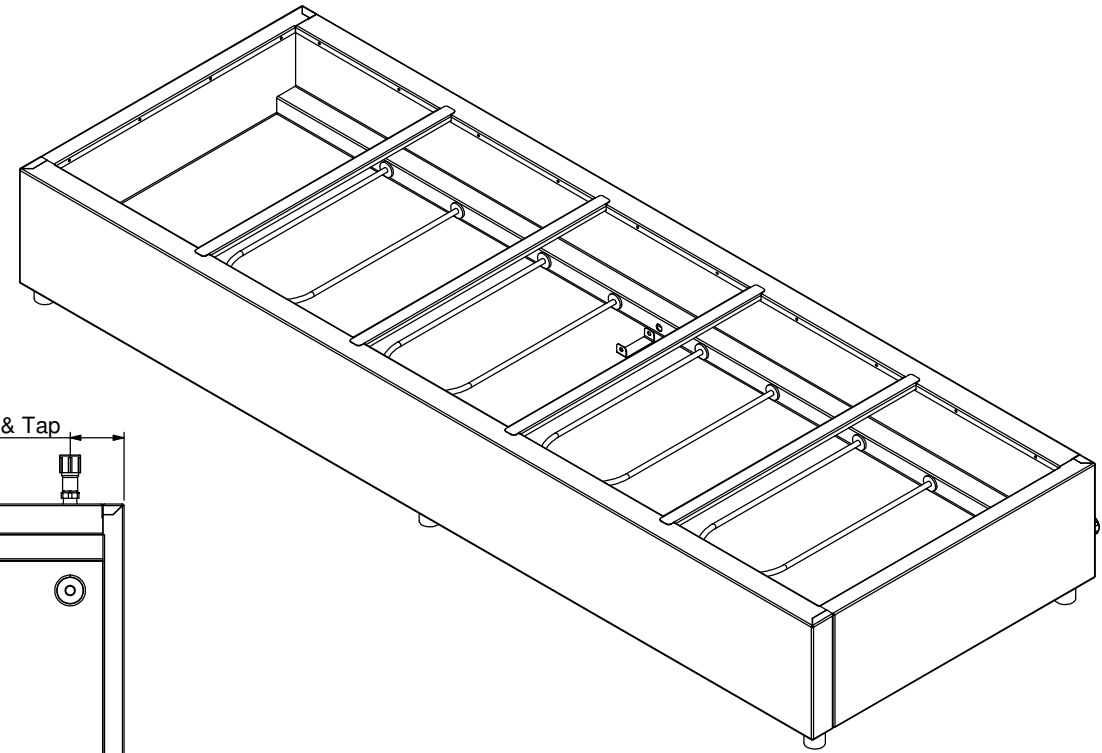

Press:	Programmed by:	Date:	Punch:	Die:
--------	----------------	-------	--------	------

STODDART
METAL FABRICATORS
TOM STODDART Pty Ltd ACN 009 690 251
215 Jackson Rd Sunnybank Hills Qld 4109
PO Box 420 Sunnybank Qld 4109
Phone (617) 3345 5011 Fax (617) 3344 1000
Email sunnybank@stoddart.com.au
Quality in stainless steel

PRODUCT: Woodson 5 Bay Bain Marie				PART No: WBMA25-A001	
DRAWN	N Wooler	SIGNATURE	DATE	UNLESS OTHERWISE SPECIFIED: DIMENSIONS ARE IN MILLIMETERS	
APPV'D			3/08/2004	DESCRIPTION: Assembly	
			MATERIAL:	REVISION	
			THICKNESS:	A	
			FINISH:	DWG No: WBMA25-D001	
DO NOT SCALE DRAWING		This drawing remains the property of Tom Stoddart Pty Ltd & cannot be reproduced without prior permission.			Sheet 1 of 19