

Product Details

- Electrical Connection : Supply single phase
 : 240v, 10amps, 2400w, 10amp plug & lead supplied
 : 1 fluoro light @ 58w (240V)
- Waste : 13mm with 19mm drain
- Unit Controls : Switch for main power with electronic thermostat
 : Switch for light
- Refridgeration Components : 1 cross fin coil
 : 1 condenser unit

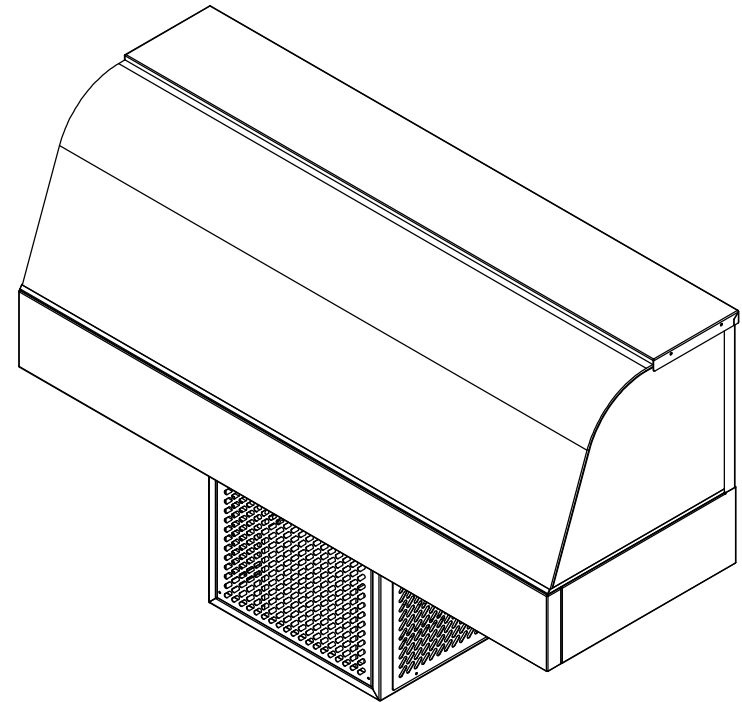
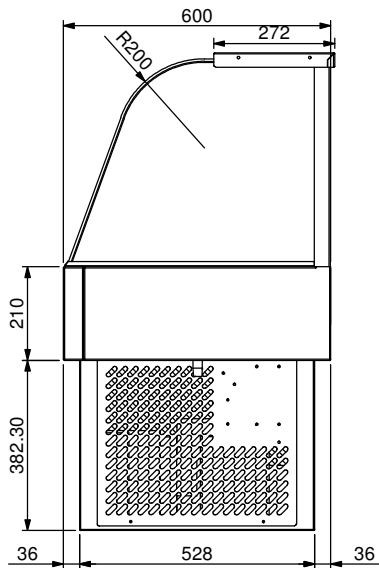
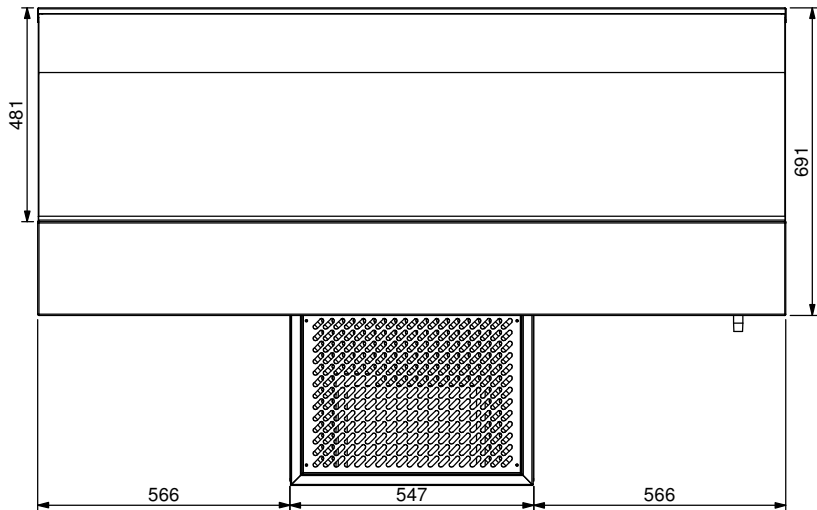
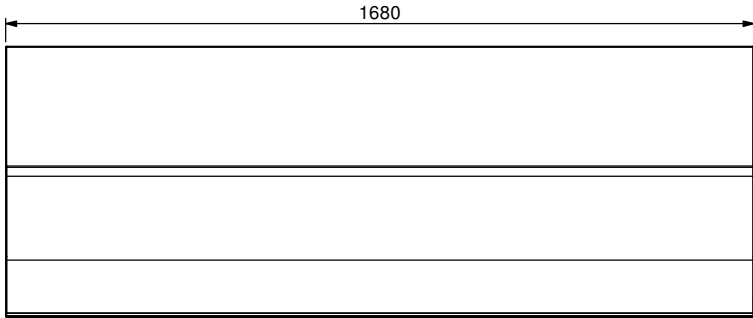

Press:	Programmed by:	Date:	Punch:	Die:
--------	----------------	-------	--------	------

STODDART
 METAL FABRICATORS
 TOM STODDART Pty Ltd ACN 009 690 251
 215 Jackson Rd Sunnybank Hills Qld 4109
 PO Box 420 Sunnybank Qld 4109
 Phone (617) 3345 5011 Fax (617) 3344 1000
 Email sunnybank@stoddart.com.au
Quality in stainless steel

PRODUCT: 5 Bay Cold Food Display-Curved Glass				PART No: WCFS25-A001	
DRAWN	N Wooler	SIGNATURE	DATE	UNLESS OTHERWISE SPECIFIED: DIMENSIONS ARE IN MILLIMETERS	
APPVD				DESCRIPTION: Curve Glass	
			MATERIAL:		REVISION
			THICKNESS:		A
			FINISH:		
DWG No: WCFC25-D001					
DO NOT SCALE DRAWING		This drawing remains the property of Tom Stoddart Pty Ltd & cannot be reproduced without prior permission.			A3
					Sheet 1 of 8