

Product Details

- Electrical Connection : Supply single phase
 : 240v, 10amps, 990w, 10amp plug and lead supplied
 : 2 fans @ 480w (240V)
 : 1 Fluro light 900mm long @ 30w (240V)
 Unit Controls : Switch for each fan setting
 : Switch for fluro light

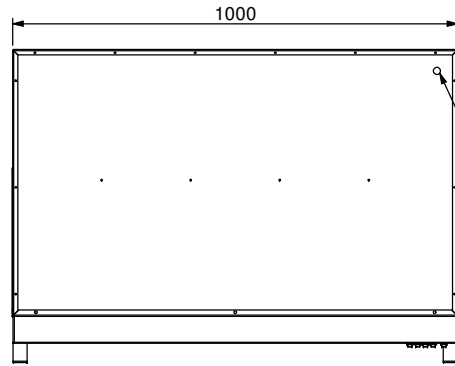

POWER SUPPLY CORD OUTLET

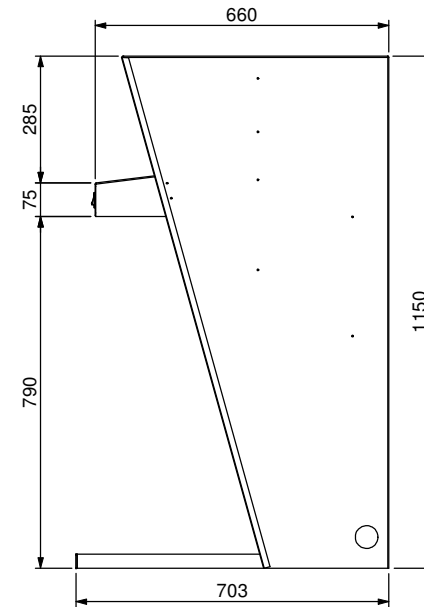
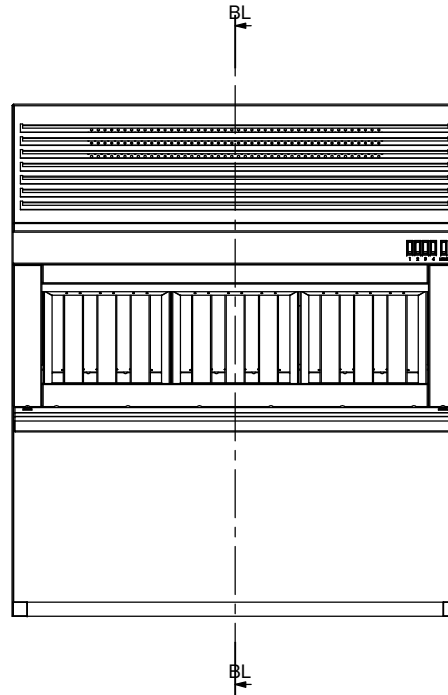
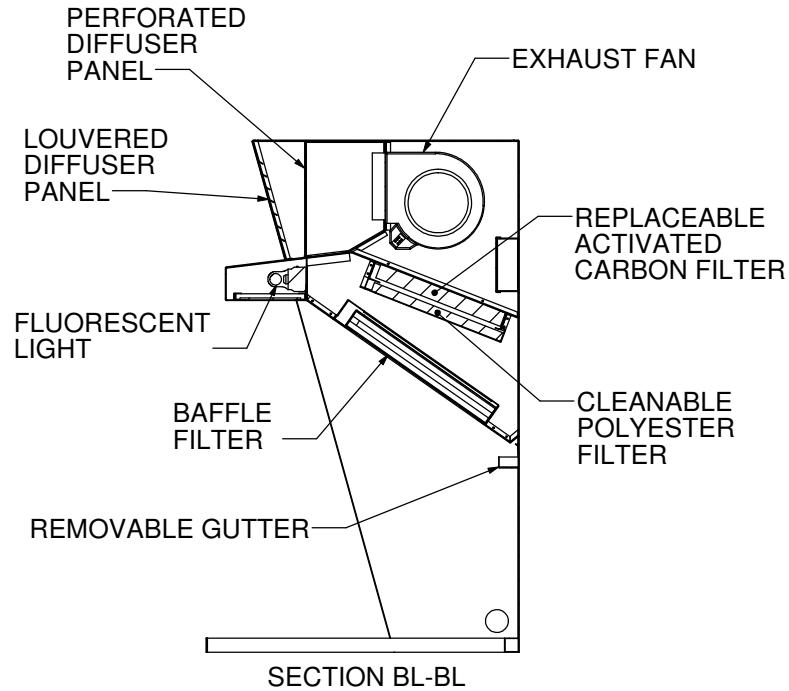
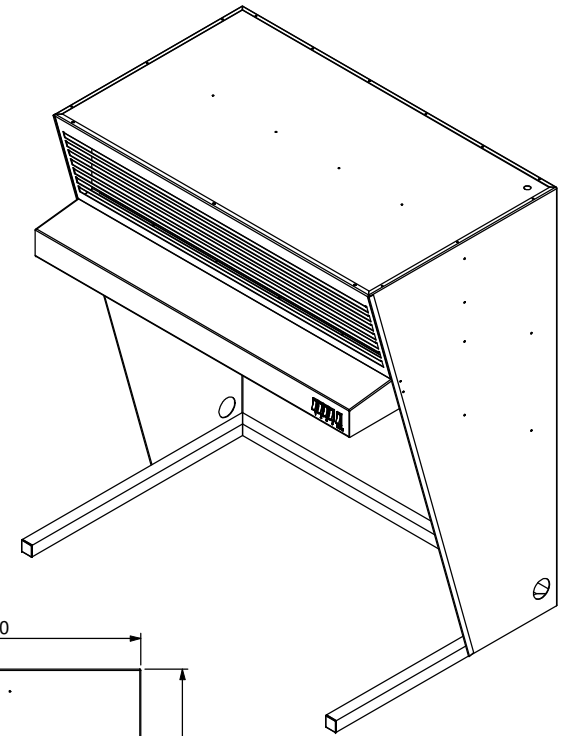

Press:	Programmed by:	Date:	Punch:	Die:
--------	----------------	-------	--------	------

STODDART
 METAL FABRICATORS
 TOM STODDART Pty Ltd ACN 009 690 251
 215 Jackson Rd Sunnybank Hills Qld 4109
 PO Box 420 Sunnybank Qld 4109
 Phone (617) 3345 5011 Fax (617) 3344 1000
 Email sunnybank@stoddart.com.au
Quality in stainless steel

PRODUCT: 1000 Long Counter Top Ductless Hood				PART No: WCHD1000-A001	
NAME	SIGNATURE	DATE	UNLESS OTHERWISE SPECIFIED: DIMENSIONS ARE IN MILLIMETERS	DESCRIPTION: Assembly	
DRAWN N Wooler		20/04/2006			
APPV/D			MATERIAL:	DWG No: WCHD1000-D001	
			THICKNESS:	REVISION A	
			FINISH:		
DO NOT SCALE DRAWING			This drawing remains the property of Tom Stoddart Pty Ltd & cannot be reproduced without prior permission.		