

Product Details

- Electrical Connection : Supply single phase
 : 240v, 15amps, 3200w, 2 of 15amp plug & lead supplied
 : 2 element @ 3200w (240V)
 Pan Size : 1/2 x 200 deep, 2 of
 Unit Controls : Knob with 205deg thermostat and indicator light
 : Reset button for 238deg thermal overload

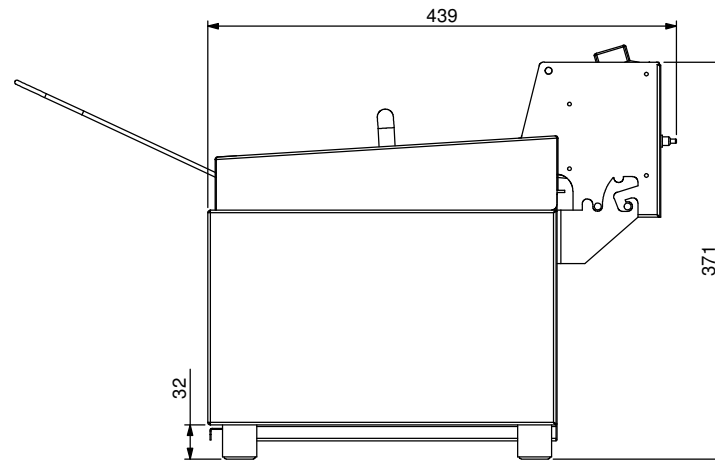
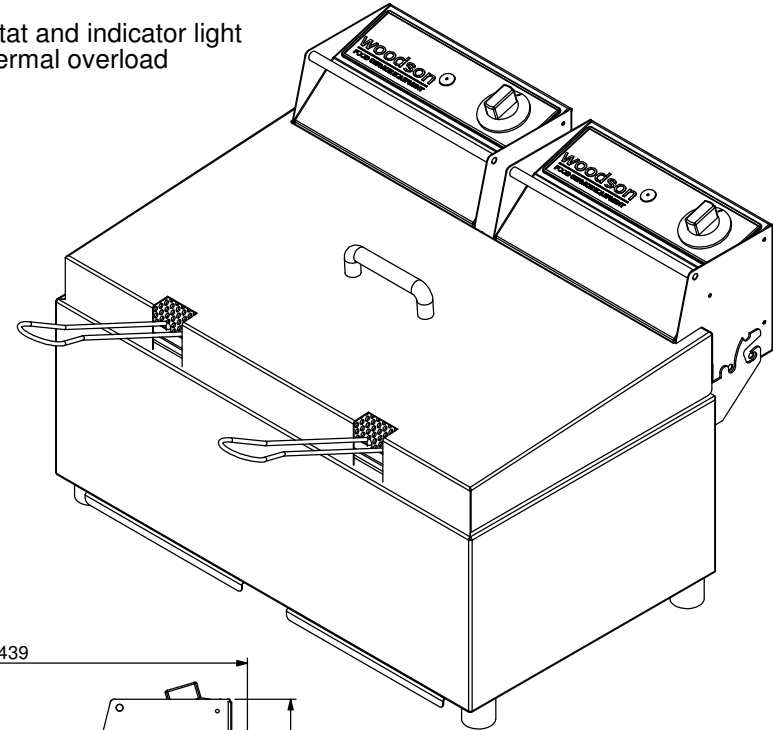

Press:	Programmed by:	Date:	Punch:	Die:
--------	----------------	-------	--------	------

STODDART
 METAL FABRICATORS
 TOM STODDART Pty Ltd ACN 009 690 251
 215 Jackson Rd Sunnybank Hills Qld 4109
 PO Box 420 Sunnybank Qld 4109
 Phone (617) 3345 5011 Fax (617) 3344 1000
 Email sunnybank@stoddart.com.au
Quality in stainless steel

PRODUCT: 8L Twin Pan Fryer				PART No: WFRT80-A001	
DRAWN	N Wooler	SIGNATURE	DATE	UNLESS OTHERWISE SPECIFIED: DIMENSIONS ARE IN MILLIMETERS	
APPV'D			21/06/2004	DESCRIPTION: Assembly	
			MATERIAL: 0.9 430 B/A	DWG No: WFRT80-D001	
			THICKNESS:	REVISION	
			FINISH: B/A	A	
DO NOT SCALE DRAWING		This drawing remains the property of Tom Stoddart Pty Ltd & cannot be reproduced without prior permission.			A3
					Sheet 1 of 21