

ITEM NO.	PART NUMBER	DESCRIPTION	Rev	Drawing Number	QTY.
1	WCFS23SS-A002	Body	C	WCFS23SS-A002	1
2	WCFS2xSS-CH-A001	Compressor Housing	C	WCFS2xSS-CH-D001	1

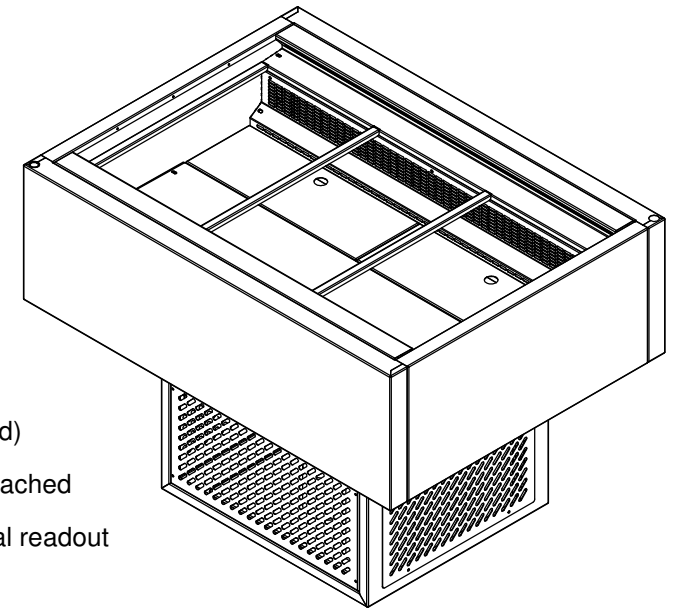

Product Details

Electrical Connection: 10A Plug & Lead (supplied)
 Electrical Rating : 240V, 4.2A, 1000W,
 Waste : 20mm with drain hose attached
 Unit Controls : Switch for main power
 : Carel controller with digital readout

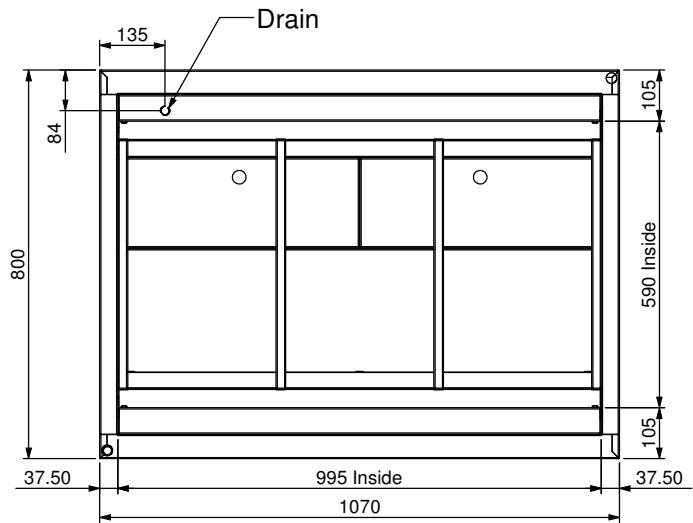
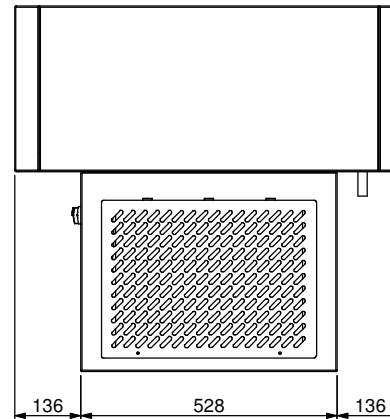
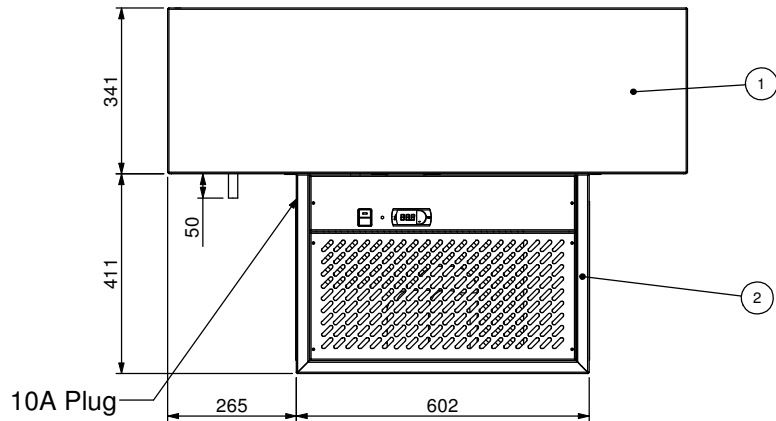

Press:	Programmed by:	Date:	Punch:	Die:
--------	----------------	-------	--------	------

STODDART
 METAL FABRICATORS
 TOM STODDART Pty Ltd ACN 009 690 251
 215 Jackson Rd Sunnybank Hills Qld 4109
 PO Box 420 Sunnybank Qld 4109
 Phone (617) 3345 5011 Fax (617) 3344 1000
 Email sunnybank@stoddart.com.au
Quality in stainless steel

PRODUCT: Cold Self Serve 3 bay Flat Deck				PART No: WCFN23SS-A001	
NAME	SIGNATURE	DATE	UNLESS OTHERWISE SPECIFIED: DIMENSIONS ARE IN MILLIMETERS	DESCRIPTION: General Drawing	
DRAWN C Booth		14/11/2006			
APPVD			MATERIAL:	DWG No: WCFN23SS-D001	
			THICKNESS:	REVISION	
			FINISH:	A	
DO NOT SCALE DRAWING			This drawing remains the property of Tom Stoddart Pty Ltd & cannot be reproduced without prior permission.		
			A3	Sheet 1 of 3	