

ITEM NO.	PART NUMBER	DESCRIPTION	Rev	Drawing Number	QTY.
1	WCFS25SS-A002	Body	C	WCFS25SS-D002	1
2	WCFS25SS-A003	Gantry	D	WCFS25SS-D003	1
3	WCFS2xSS-CH-A001	Compressor Housing	C	WCFS2xSS-CH-D001	1

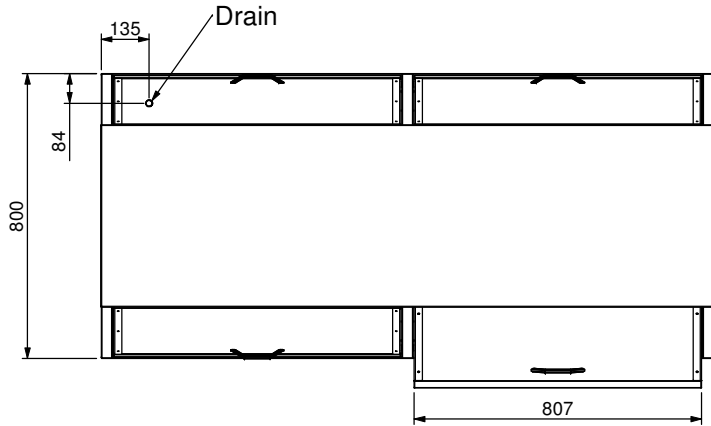

**Product Details**

Electrical Connection: 10Amp Plug & Lead (supplied)  
 Electrical Rating : 240V, 5.9A, 1400W  
 Waste : 20mm with drain hose attached  
 Unit Controls : Switch for main power  
 : Carel controller with digital readout

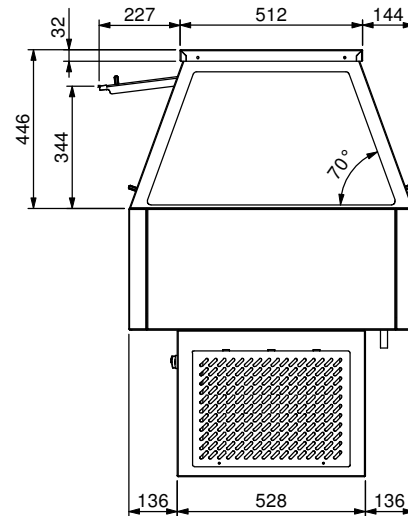
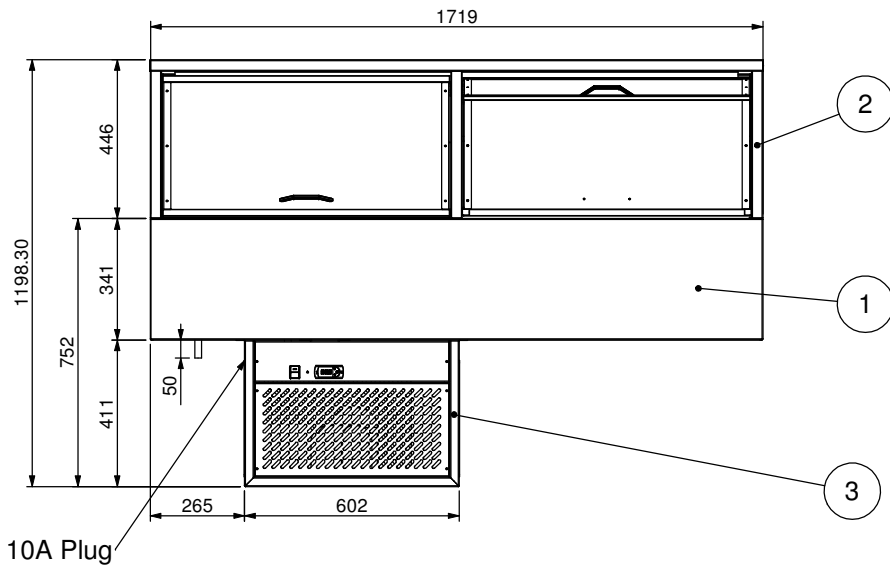
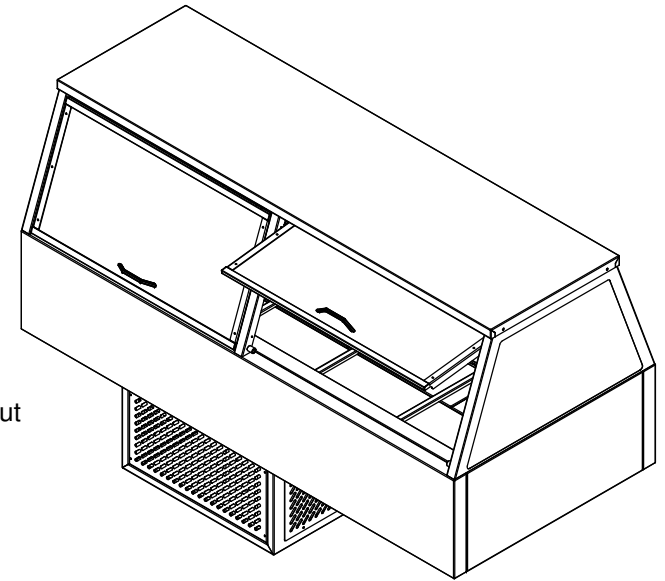

**STODDART**  
 METAL FABRICATORS  
 TOM STODDART Pty Ltd ACN 009 690 251  
 215 Jackson Rd Sunnybank Hills Qld 4109  
 PO Box 420 Sunnybank Qld 4109  
 Phone (617) 3345 5011 Fax (617) 3344 1000  
 Email sunnybank@stoddart.com.au  
*Quality in stainless steel*

PRODUCT: Cold Self Serve 5 Bay			
NAME	SIGNATURE	DATE	UNLESS OTHERWISE SPECIFIED: DIMENSIONS ARE IN MILLIMETERS
DRAWN C Booth		23/11/2004	
APPV'D			MATERIAL: THICKNESS: FINISH:
DO NOT SCALE DRAWING		This drawing remains the property of Tom Stoddart Pty Ltd & cannot be reproduced without prior permission.	

Press:	Programmed by:	Date:
PART No: <b>WCFS25SS-A001</b>		
DESCRIPTION: General Drawing		
DWG No: <b>WCFS25SS-D001</b>		REVISION <b>D</b>
A3		Sheet 1 of 3