

ITEM NO.	PART NUMBER	DESCRIPTION	Spare Parts/QTY.
13	CMEL-0556	1100W Element	2
14	CMGE-0386	WGDC10 Decal	1
15	CMEL-0540	Indicator Light	1
16	CMEL-0698	Thermostat Knob-Blank	1
17	CMGE-0276	32x32 Foot w/Washer	4
18	CMEL-0337	Thermostat 250deg	1
29	CMGE-0399	Torsion Spring	2

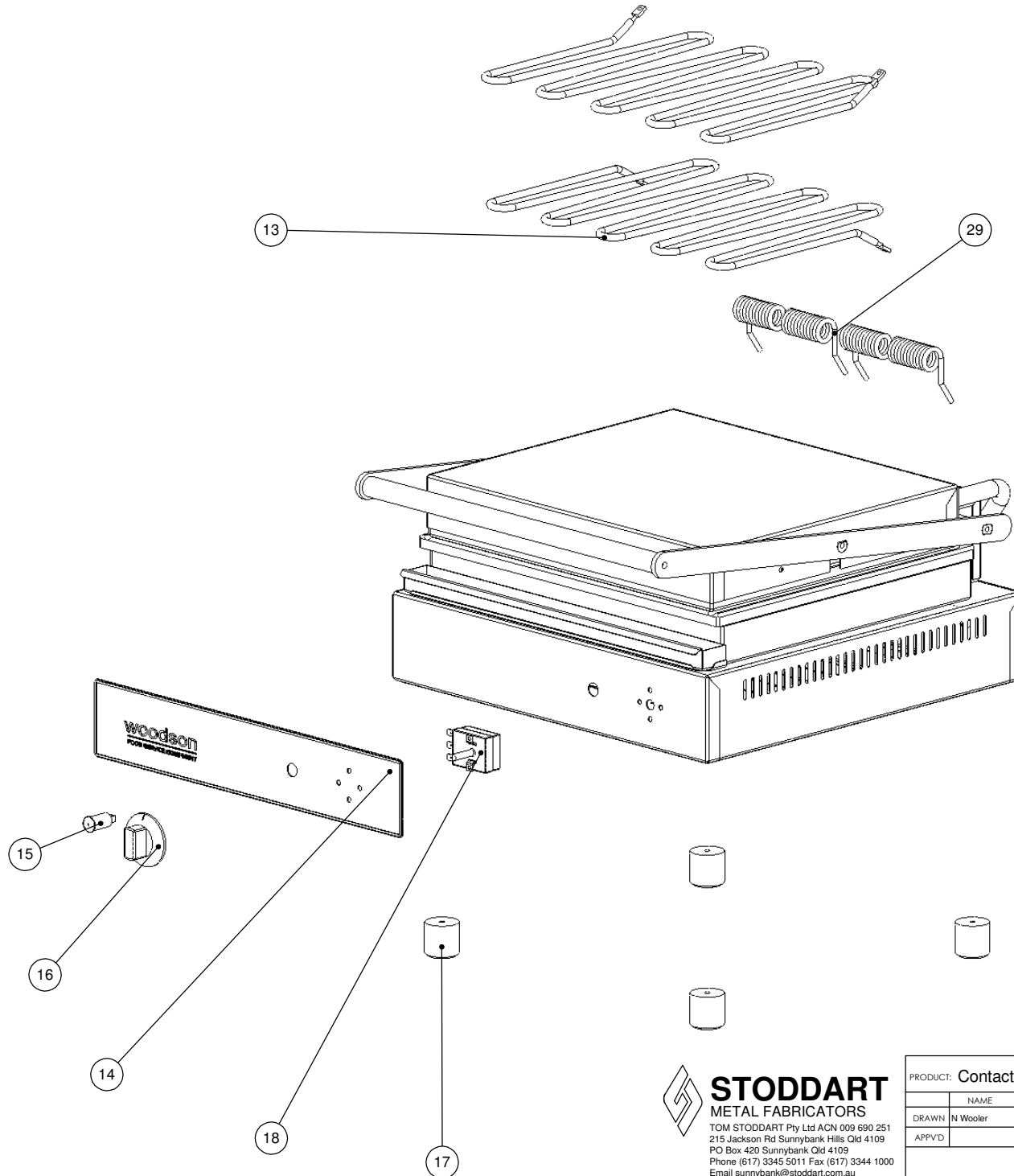

Press:	Programmed by:	Date:	Punch:	Die:
--------	----------------	-------	--------	------

STODDART
 METAL FABRICATORS
 TOM STODDART Pty Ltd ACN 009 690 251
 215 Jackson Rd Sunnybank Hills Qld 4109
 PO Box 420 Sunnybank Qld 4109
 Phone (617) 3345 5011 Fax (617) 3344 1000
 Email sunnybank@stoddart.com.au
Quality in stainless steel

PRODUCT: Contact Toaster				PART No: WCT6-A001	
DRAWN	N Wooler	SIGNATURE	DATE	UNLESS OTHERWISE SPECIFIED: DIMENSIONS ARE IN MILLIMETERS	
APPVD			26/11/2008	DESCRIPTION: Spare Parts	
			MATERIAL: 0.9 430 B/A	REVISION	
			THICKNESS:	DWG No: WCT6-D001	
			FINISH:	A	
DO NOT SCALE DRAWING		This drawing remains the property of Tom Stoddart Pty Ltd & cannot be reproduced without prior permission.			Sheet 3 of 29