

**Product Details**

Electrical Connection : Supply 15amp single phase  
 : 240v, 15amps, 3250w, 15amp plug & lead supplied  
 : 6 elements @ 545w (240V)  
 Unit Controls : Knob for 15min timer with indicator light  
 : Knob for energy regulator for top elements  
 : Knob for energy regulator for bottom elements  
 : Toggle switch for either top only or top & bottom element operation

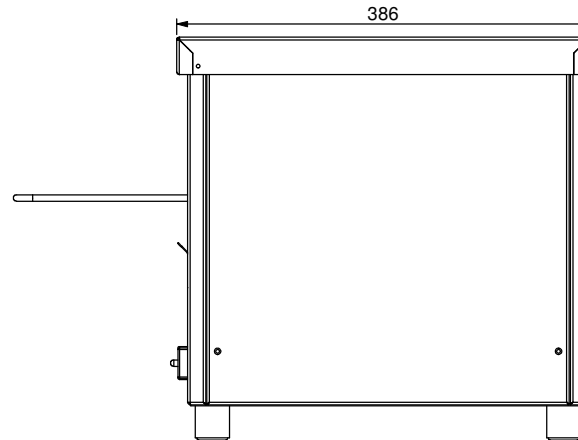
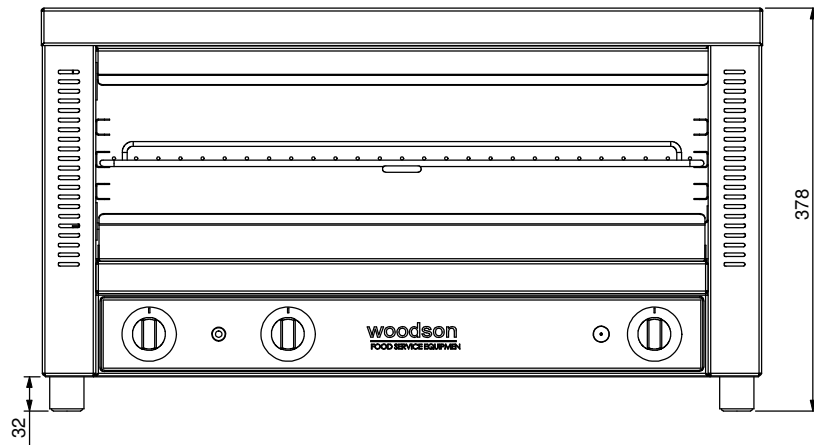
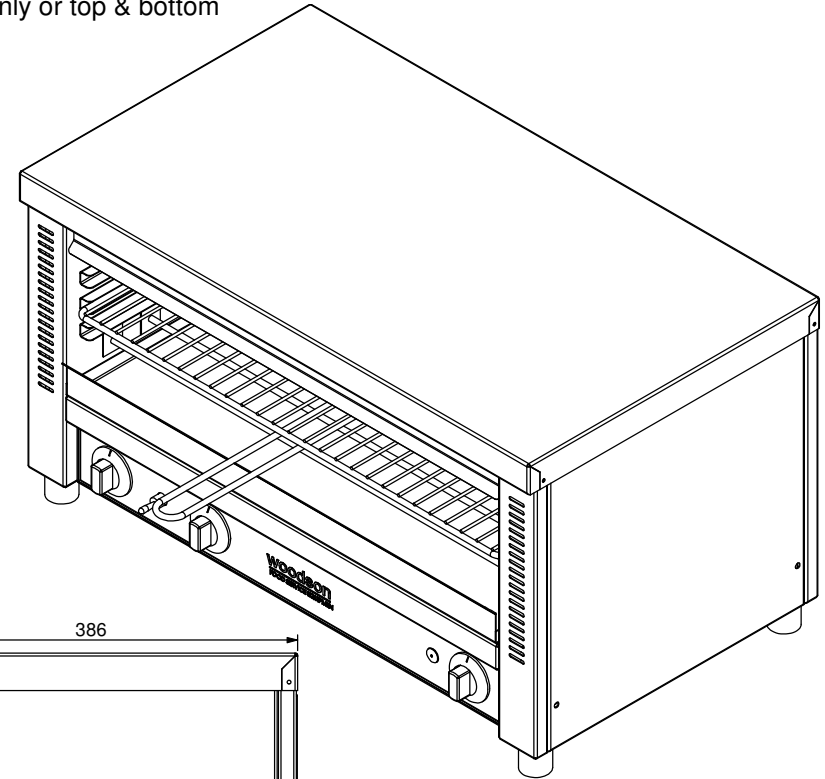
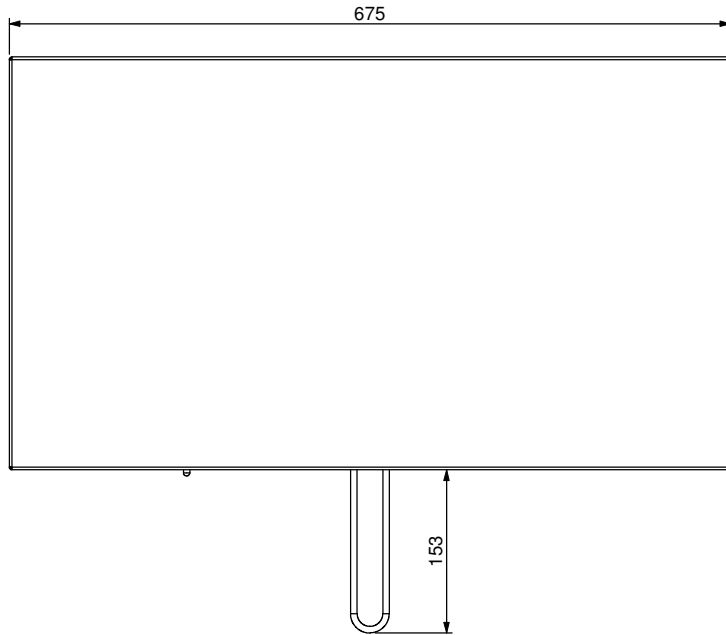

Press:	Programmed by:	Date:	Punch:	Die:
--------	----------------	-------	--------	------

**STODDART**  
 METAL FABRICATORS  
 TOM STODDART Pty Ltd ACN 009 690 251  
 215 Jackson Rd Sunnybank Hills Qld 4109  
 PO Box 420 Sunnybank Qld 4109  
 Phone (617) 3345 5011 Fax (617) 3344 1000  
 Email sunnybank@stoddart.com.au  
*Quality in stainless steel*

PRODUCT: Large Infra-Red Toaster				PART No: <b>WGLI150-A001</b>	
NAME	SIGNATURE	DATE	UNLESS OTHERWISE SPECIFIED: DIMENSIONS ARE IN MILLIMETERS	DESCRIPTION: General Drawing	
DRAWN N Wooler		11/05/2006			
APPV'D			MATERIAL: 0.9 430 B/A	DWG No: <b>WGLI150-D001</b>	
			THICKNESS: FINISH: B/A	REVISION <b>B</b>	
DO NOT SCALE DRAWING		This drawing remains the property of Tom Stoddart Pty Ltd & cannot be reproduced without prior permission.			A3
					Sheet 1 of 18

REV.	NAME	DATE	DESCRIPTION
B	M Sheehan	15/01/2008	Extra shelf runner added