

**Product Details**

Electrical Connection : 10 Amp Plug & Lead Supplied  
 Electrical Rating : 240v, 6.25amps, 1500w,  
 : 2 elements @ 600w  
 : 1 Woodson Heat Lamp Unit @ 300w  
 Waste : 13mm with 19mm drain  
 and 1/2" BSP mini cistern cock  
 Unit Controls : Switch for main power and heat lamp  
 : Knob for thermostat with dial thermometer

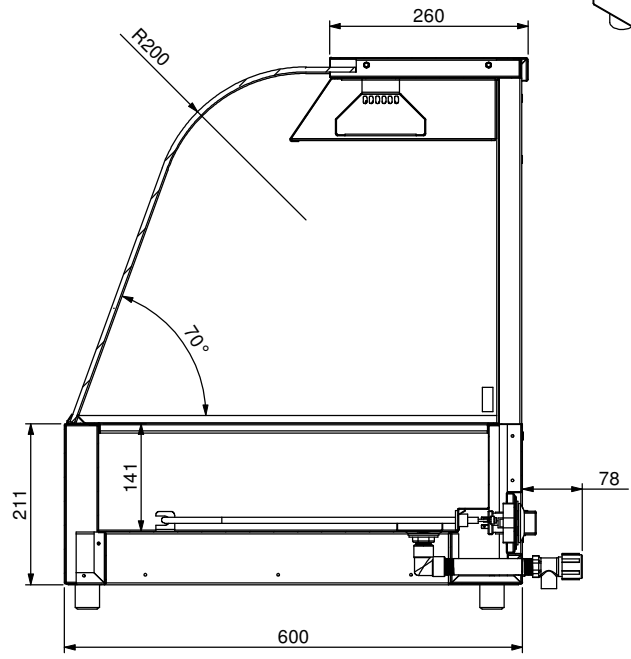
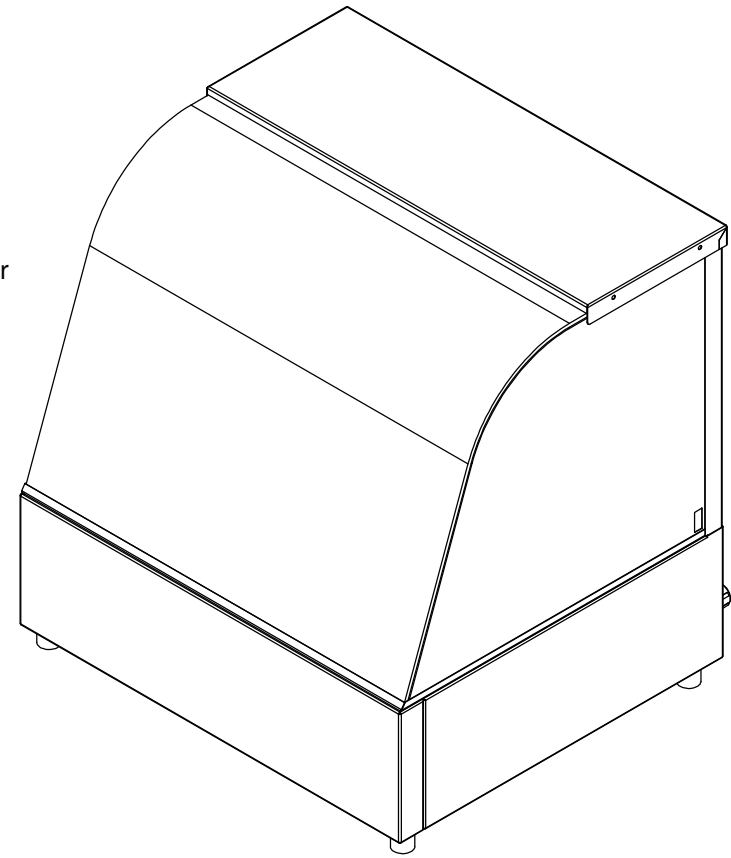

SECTION H-H

Press:	Programmed by:	Date:	Punch:	Die:
--------	----------------	-------	--------	------

**STODDART**  
 METAL FABRICATORS  
 TOM STODDART Pty Ltd ACN 009 690 251  
 215 Jackson Rd Sunnybank Hills Qld 4109  
 PO Box 420 Sunnybank Qld 4109  
 Phone (617) 3345 5011 Fax (617) 3344 1000  
 Email sunnybank@stoddart.com.au  
*Quality in stainless steel*

PRODUCT: 2 Bay Hot Food Display - Curved Glass				PART No: <b>WHFS22-A001</b>	
DRAWN	N Wooler	SIGNATURE	DATE	UNLESS OTHERWISE SPECIFIED: DIMENSIONS ARE IN MILLIMETERS	
APPVD			22/07/2008	DESCRIPTION: General Drawing	
			MATERIAL:	REVISION	
			THICKNESS:	A	
			FINISH:	DWG No: WHFC22-D001	
DO NOT SCALE DRAWING			This drawing remains the property of Tom Stoddart Pty Ltd & cannot be reproduced without prior permission.		
			A3	Sheet 1 of 8	