

Product Details

Electrical Connection : 10 Amp Plug & Lead (supplied)
 Electrical Rating : 240v, 6.25amps, 1500w,
 : 2 elements @ 600w
 : 1 Woodson Heat Lamp Unit @ 300w
 Waste : 13mm with 19mm drain
 and 1/2" BSP mini cistern cock
 Unit Controls : Switch for main power and heat lamp
 : Knob for thermostat with dial thermometer

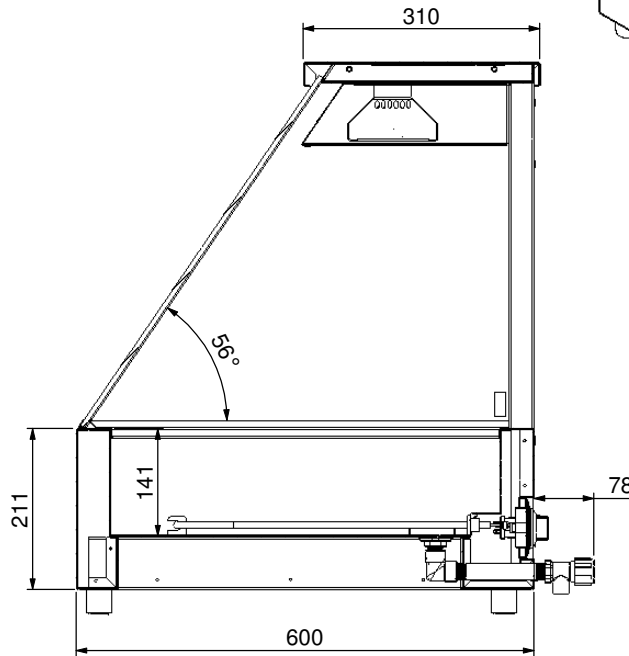
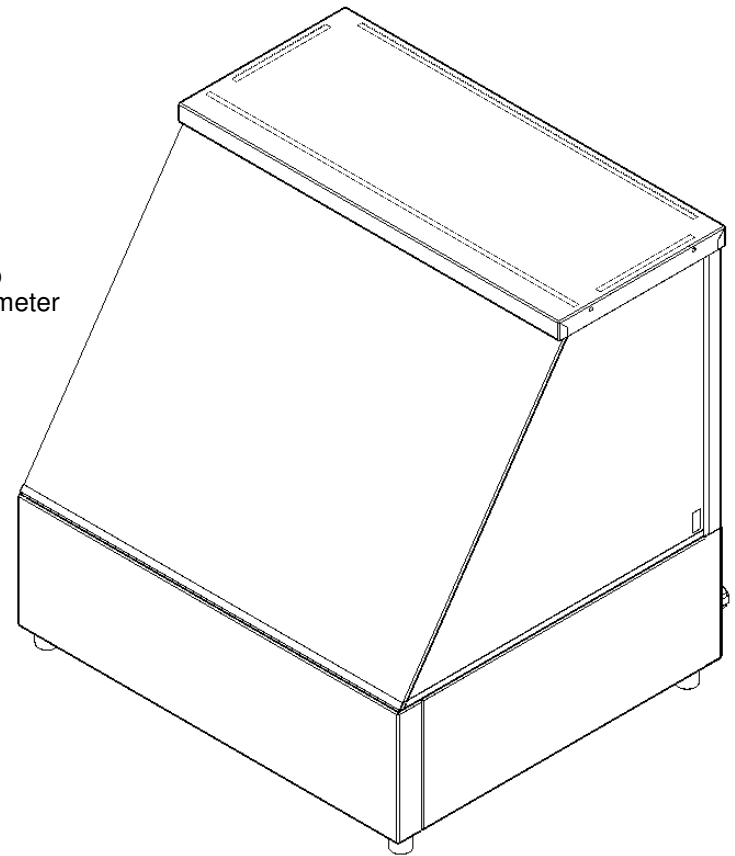

SECTION CJ-CJ

Press:	Programmed by:	Date:	Punch:	Die:
--------	----------------	-------	--------	------

STODDART
 METAL FABRICATORS
 TOM STODDART Pty Ltd ACN 009 690 251
 215 Jackson Rd Sunnybank Hills Qld 4109
 PO Box 420 Sunnybank Qld 4109
 Phone (617) 3345 5011 Fax (617) 3344 1000
 Email sunnybank@stoddart.com.au
Quality in stainless steel

PRODUCT: 2 Bay Hot Food Display				PART No: WHFS22-A001	
DRAWN	N Wooler	SIGNATURE	DATE	UNLESS OTHERWISE SPECIFIED: DIMENSIONS ARE IN MILLIMETERS	
APPVD				DESCRIPTION: General Drawing	
			MATERIAL:		REVISION
			THICKNESS:		A
			FINISH:		
DO NOT SCALE DRAWING		This drawing remains the property of Tom Stoddart Pty Ltd & cannot be reproduced without prior permission.			DWG No: WHFS22-D001
				A3	Sheet 1 of 33