

Product Details

- Electrical Connection : Supply single phase
 : 230v, 6.6amps, 1513w, 10amp plug & lead supplied
 : 2 elements @ 600w (230V)
 : 1 heat lamps @ 300w (230V)
 : 1 flouro light @ 13w (230V)
- Unit Controls : Switch for main power, flouro, and heat lamps
 : Dimmer switch to control heat lamps
- Door Opening : Knob for thermostat with dial thermometer
 : 342 x 385

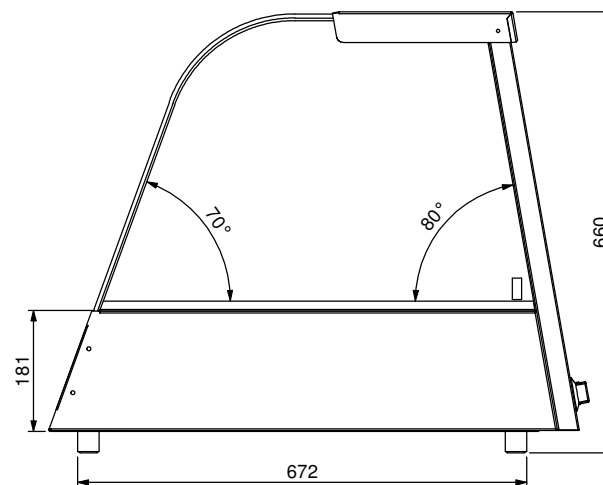

Press:	Programmed by:	Date:	Punch:	Die:
--------	----------------	-------	--------	------

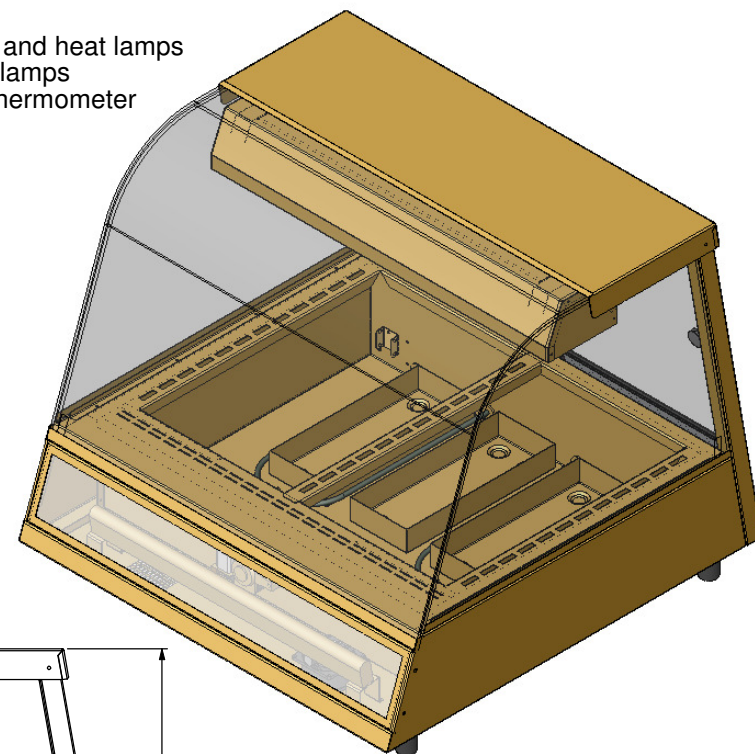

**STODDART
MANUFACTURING**

TOM STODDART Pty Ltd ACN 009 690 251
 215 Jackson Rd Sunnybank Hills Qld 4109
 P.O. Box 420 Sunnybank Qld 4109
 Phone: (617) 3344 2444 Fax: (617) 3344 6403
 Email: sunnybank@stoddart.com.au

Quality in stainless steel

PRODUCT: 2 Module Chicken Display Heated				PART No: WPHC.22-A001	
DRAWN	NAME	SIGNATURE	DATE	UNLESS OTHERWISE SPECIFIED: DIMENSIONS ARE IN MILLIMETERS	
	N Wooler		25/02/2009	DESCRIPTION: General Drawing	
APPVD				MATERIAL:	REVISION
	Weight: 55.24 kg			THICKNESS:	
	Surface Area: 11.61 M2			FINISH:	
DO NOT SCALE DRAWING		This drawing remains the property of Tom Stoddart Pty Ltd & cannot be reproduced without prior permission.			A3
				Sheet 1 of 33	