



# contact toaster 4/6 slice

**MODEL: WCT6**

**APPLICATIONS**

- Ideal for toasting sandwiches, focaccias, kebabs etc.

**CAPACITY GUIDE**

- 4-6 slices on large 393mm x 338mm plates

**STANDARD FEATURES**

- Bottom and top heated plates hold heat for fast, flavourful and extremely even toasting
- Spring balanced top platen forms the optimum seal around food
- Ultra-smooth plate with drain groove to front makes cleaning easier
- Full stainless steel body and lift mechanism including insulated handle - heavy duty construction means longer life
- Removable front mounted grease tray
- Flexible metal conduit to upper plate, with cast fitting to base to prevent damage
- Thermostat control & indicator light
- Non-slip rubber feet





**WCT6**

**SPECIFICATIONS**

	Kw 2.1	Amps 10
Width	415	Depth 505
		Height 240

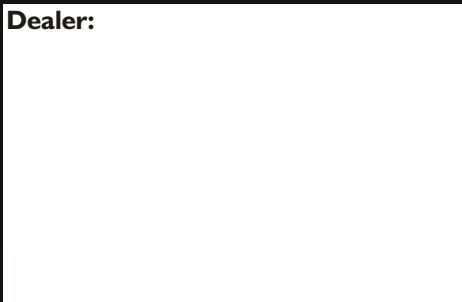
**Dealer:**



 Power cable located at rear of unit on the left hand end.

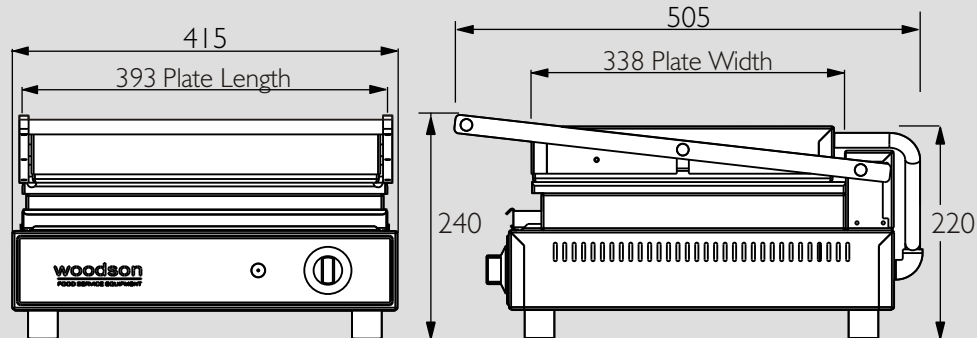

We reserve the right to alter specifications of products without notice

**For details of  
your local  
dealer contact:**

**QLD**  
Tel: 07 3344 2444  
Fax: 07 3345 6403  
fse@stoddart.com.au

**NSW**  
Tel: 02 8846 5999  
Fax: 02 8846 5900  
sydney@stoddart.com.au

**VIC & TAS**  
Tel: 03 9584 5677  
Fax: 03 9584 6744  
melbourne@stoddart.com.au

**WA**  
Tel: 08 9418 2477  
Fax: 08 9418 2588  
perth@stoddart.com.au

**SA & NT**  
Tel: 1300 79 1954  
adelaide@stoddart.com.au